

# SG·SA Sewage pump



## Features

- The open type impeller can handle water containing soil and sand through the strainer.
- The Oil bath mechanical seal guarantees reliable sealing and long service.
- The Auto thermal motor protector is built-in.

## Standard Specifications

Pumping Fluid	Type of Fluid	Natural water, Filty water
	Fluid Temperature	0-40°C (Without freezing)
Structure	Impeller	semi-open
	Shaft Seal	Mechanical Seal
	Bearing	Ball bearing
Material	Casing	Plastic
	Impeller	Plastic
	Shaft	SUS420J1
Motor	Type	Original motor
	Power	1 Phase 100V
	Pole	2 Pole

## Uses

- Civil engineering & construction
- Industrial uses
- Building facility
- Sewage disposal
- Agriculture
- Fishery

## Size

SG-150C

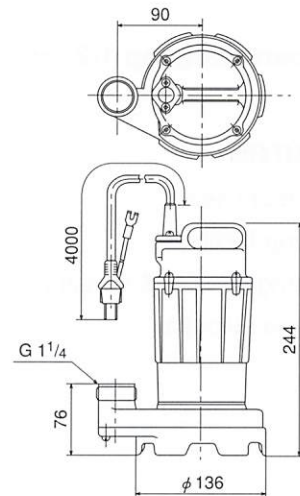

SA-150C

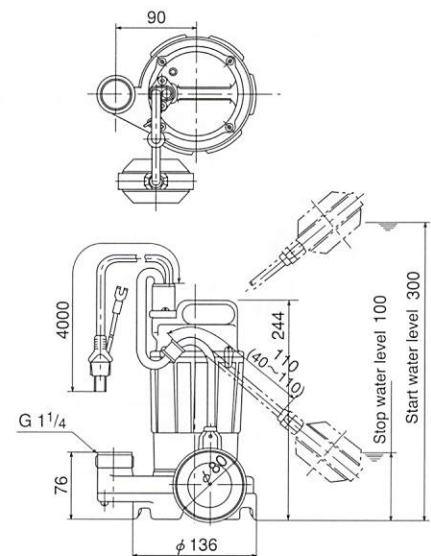

## Special Specifications

Please specify voltage for each pump on your order.  
Please contact us for custom specifications.

## Performance Curve

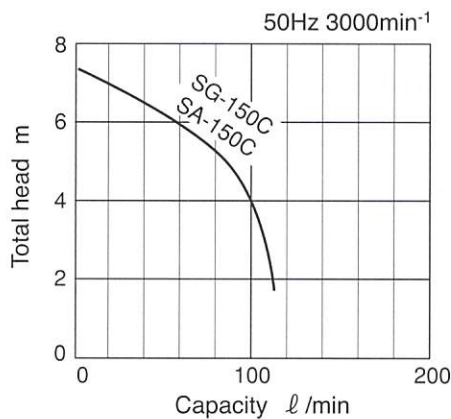

## Specifications

Bore mm	Model	Capacity ℓ /min	Total head m	50Hz 3000min <sup>-1</sup>	
				Output W	Weight kg
32	SG-150C	80	5	150	4.3
	SA-150C	80	5	150	4.6