

φ100×φ80 □TJSM-108C		[メカニカルシール式] 構造断面図 CONSTRUCTION OF CENTRIFUGAL PUMP		御注文主 CUSTOMER		
				用途 USED FOR		
				殿		
機番 ITEM NO.	製番 MFG. NO.	吐出し量 CAPACITY	全揚程 TOTAL HEAD	出力 OUT PUT	同期速度 SPEED	台数 QUANTITY
		m ³ /min	m	kW	min ⁻¹	

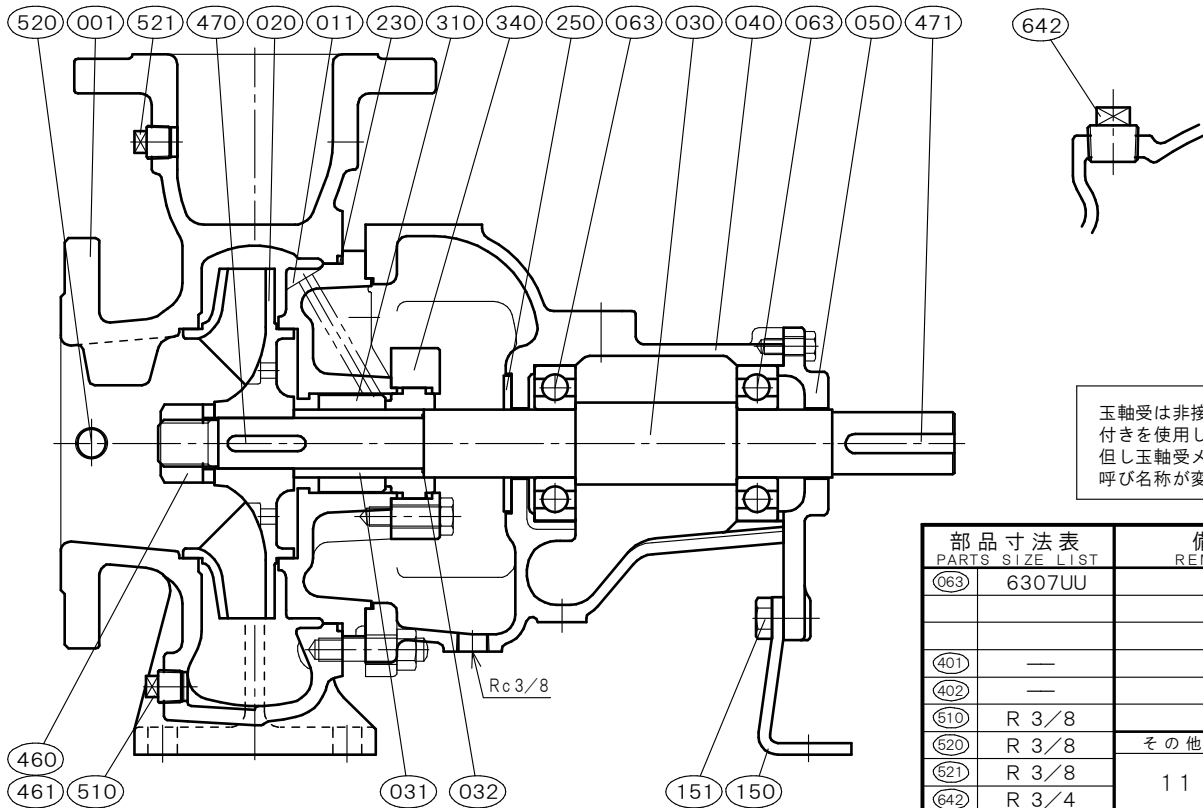

部品寸法表 PARTS SIZE LIST		備考 REMARKS
(063)	6307UU	
(401)	—	
(402)	—	
(510)	R 3/8	
(520)	R 3/8	その他 NOTE
(521)	R 3/8	
(642)	R 3/4	11・15kW

NO.	部品名 NAME OF PART		材質 MATERIAL		個数 QUAN.	NO.	部品名 NAME OF PART		材質 MATERIAL		個数 QUAN.
	SCS13	SCS14	SCS13	SCS14			SCS13	SCS14			
001	ケーシング	CASING	SCS13	SCS14	1	642	呼び水プラグ	PRIMING PLUG	SUS304	SUS316	1
011	ケーシングカバー	CASING COVER	SCS13	SCS14	1						
020	羽根車	IMPELLER	SCS13	SCS14	1						
030	主軸	SHAFT	SUS304	SUS316	1						
031	スリーブ	SHAFT SLEEVE	SUS304	SUS316	1						
032	スリーブパッキン	SLEEVE PACKING	PTFE	PTFE	1						
040	軸受	METAL CASING	FC200	FC200	1						
050	軸受カバー	BEARING COVER	FC200	FC200	1						
063	玉軸受	BALL BEARING	SUJ2	SUJ2	2						
150	軸受支え	BEARING SUPPORT	SS400	SS400	1						
151	軸受支えボルト	BOLT	SUS304	SUS304	2						
230	カバーパッキン	COVER PACKING	FKM	FKM	1						
250	水切りつば	DEFLECTOR	C R	C R	1						
310	メカニカルシール	MECHANICAL SEAL	SiCvsC	SiCvsC	1set						
340	メカカバー	MECHA COVER	SUS304	SUS316	1	標準付属品 STANDARD ACCESSORIES					
460	羽根車ナット	IMPELLER NUT	SUS304	SUS316	1	(240)	フランジパッキン	FLANGE PACKING	C R	C R	2
461	回り止め	LOCK WASHER	SUS304	SUS316L	1	(600)	共通ベッド	COMMON BASE	FC200	FC200	1
470	羽根車キー	IMPELLER KEY	SUS316	SUS316	1	(610)	軸継手	COUPLING	FC200	FC200	1set
471	軸継手キー	COUPLING KEY	S45C	S45C	1	(620)	軸継手ガード	COUPLING GUARD	SUS430orSS400		1
510	ドレン抜きプラグ	DRAIN PLUG	SUS304	SUS316	1	(650)	基礎ボルト	FOUNDATION BOLT	SS400	SS400	1set
520	真空計プラグ	VACUUM GAUGE PLUG	SUS304	SUS316	1						
521	圧力計プラグ	PRESSURE GAUGE PLUG	SUS304	SUS316	1						