

φ65×φ65 □COM-5N		[メカニカルシール式] 構造断面図 CONSTRUCTION OF SELF PRIMING PUMP		御注文主 CUSTOMER		殿	
機番 ITEM NO.		製番 MFG. NO.		吐出し量CAPACITY		全揚程 TOTAL HEAD	
				m ³ /min		m	
				出力 OUT PUT		同期速度 SPEED	
				kW		min ⁻¹	
				用途 USED FOR			
				台数 QUANTITY			

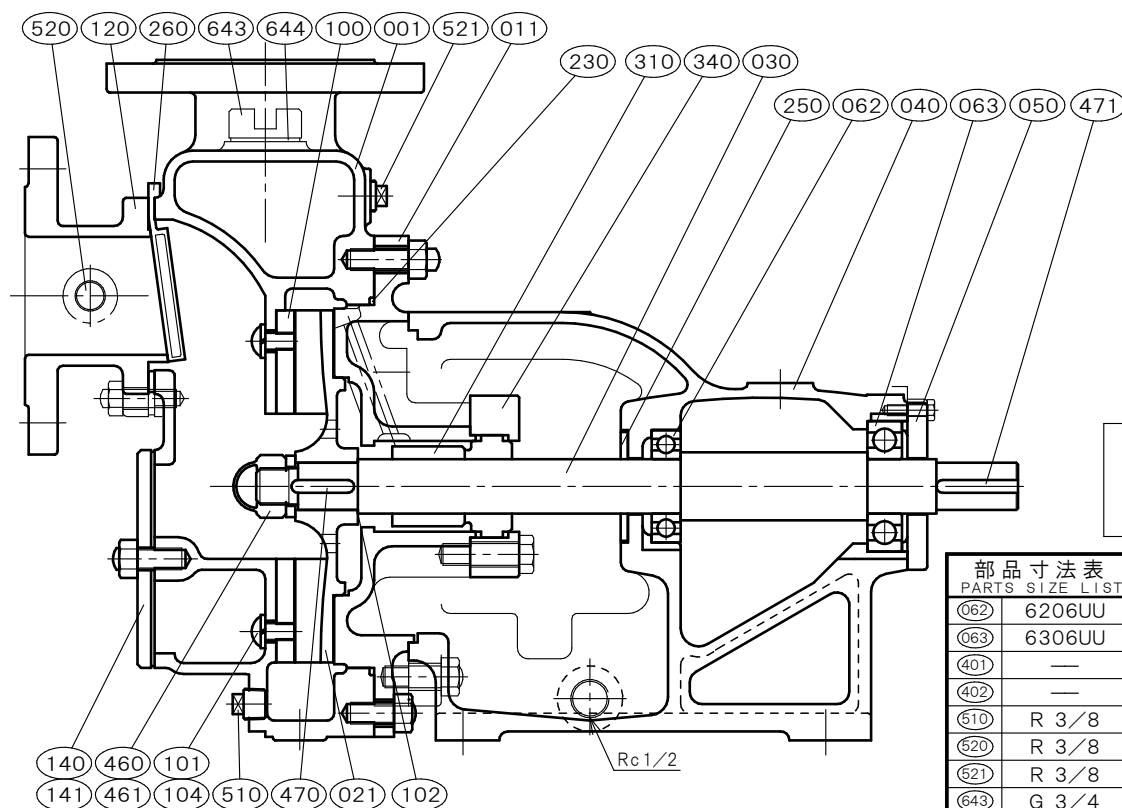

部品寸法表 PARTS SIZE LIST		備考 REMARKS
062	6206UU	
063	6306UU	
401	—	
402	—	
510	R 3/8	
520	R 3/8	
521	R 3/8	その他 NOTE
643	G 3/4	

NO.	部品名 NAME OF PART		材質 MATERIAL		個数 QUAN.	NO.	部品名 NAME OF PART		材質 MATERIAL		個数 QUAN.
			SCS13	SCS14					SCS13	SCS14	
001	ケーシング	CASING	SCS13	SCS14	1	461	回り止め	LOCK WASHER	SUS304	SUS316L	1
011	ケーシングカバー	CASING COVER	SCS13	SCS14	1	470	羽根車キー	IMPELLER KEY	SUS316	SUS316	1
021	羽根車	IMPELLER	SCS13	SCS14	1	471	軸継手キー	COUPLING KEY	S45C	S45C	1
030	主軸	SHAFT	SUS304	SUS316	1	510	ドレン抜きプラグ	DRAIN PLUG	SUS304	SUS316	1
040	軸受	METAL CASING	FC200	FC200	1	520	真空計プラグ	VACCUUM GAUGE PLUG	SUS304	SUS316	1
050	軸受カバー	BEARING COVER	FC200	FC200	1	521	圧力計プラグ	PRESSURE GAUGE PLUG	SUS304	SUS316	1
062	玉軸受	BALL BEARING	SUJ2	SUJ2	1	643	呼び水栓	PRIMING PLUG	SCS14	SCS14	1
063	玉軸受	BALL BEARING	SUJ2	SUJ2	1	644	呼び水栓パッキン	PRIMING PACKING	C R	C R	1
100	マサツ板	SIDE PLATE	SUS304	SUS316	1						
101	マサツ板取付ボルト	PLATE BOLT	SUS316	SUS316L	2						
102	調整リング	ADJUST RING	SUS316	SUS316	n						
104	マサツ板取付ワッシャー	SPRING WASHER	SUS304	SUS316L	2						
120	吸込フランジ	SUCTION FLANGE	SCS13	SCS14	1						
140	マンホールカバー	MANHOLE COVER	SUS304	SUS316	1	標準付属品 STANDARD ACCESSORIES					
141	マンホールパッキン	MANHOLE PACKING	C R	C R	1	(240)	フランジパッキン	FLANGE PACKING	C R	C R	2
230	カバーパッキン	COVER PACKING	FKM	FKM	1	(600)	共通ベッド	COMMON BASE	FC200	FC200	1
250	水切りつば	DEFLECTOR	C R	C R	1	(610)	軸継手	COUPLING	FC200	FC200	1set
260	吸水弁	SUCTION VALVE	C R (SUS316)		1	(620)	軸継手ガード	COUPLING GUARD	SUS430orSS400		1
310	メカニカルシール	MECHANICAL SEAL	SiCvsC	SiCvsC	1set	(650)	基礎ボルト	FOUNDATION BOLT	SS400	SS400	1set
340	メカカバー	MECHA COVER	SCS13	SCS14	1						
460	羽根車ナット	IMPELLER NUT	SUS304	SUS316L	1						