

TFS・TFSH



直結／非自吸／グランドパッキン・メカニカルシール



■特長

- 合理的な設計と品質管理を徹底し、高い信頼性・耐久性・部品の互換性等を実現。
- 高効率により、イニシャルコスト、ランニングコストを低減。
- 軸封部はグランドパッキン式、シングルメカニカルシール式が標準。
また、水冷式、ダブルメカニカルシール式等の製作も可能。

■標準仕様

	TFS形	TFSH形
ポンプ材質	SUS304(SCS13)、SUS316(SCS14)	
口径	32mm～200mm	25mm～150mm
使用液温度	0℃～100℃ (但し、使用液により異なります。)	
最高使用圧力	ポンプ締切り圧力 ≤ 1.1MPa	
フランジ規格	JIS 10K 並形 R.F	
構造	羽根車	クローズ形・セミオープン形 ※TFS-32・200Aはクローズ形のみ
	軸封	クローズ形・セミオープン形 ※TFSH-80A・125・150はクローズ形のみ
	軸受	グランドパッキン式、メカニカルシール式
	軸受	密封玉軸受 ※TFS-125A・150A・200・200Aは開放玉軸受使用(オイルバス式)
主軸	TFSH-100・125・150のみスリーブ付	TFS-125A・150A・200・200Aのみスリーブ付

※形式によりセミオープン形も製作可能ですので、お問い合わせください。
セミオープン形の場合、仕様・外形寸法が変わります。

■用途

- 化学工業用
- 食品工業用
- 電子産業用
- 水処理工業用
- 一般産業用
- 医薬・化粧品工業用
- 繊維・染色工業用
- 石油工業用
- 酒造・醸造工業用

■標準付属品

共通ベース	1
相フランジパッキン	2
カップリング	1組
カップリングガード	1

■特別仕様

使用液温度	-20℃～180℃ (但し、使用液により異なります。)
構造変更	軸封・・・グランドパッキン水冷式 メカニカルシール水冷式 ダブルメカニカルシール式
	軸受・・・開放玉軸受使用 (グリースアップ式) 開放玉軸受使用 (オイルバス式) 開放玉軸受使用 (メタル水冷式)
	主軸・・・スリーブ付 ※TFS-32・40、TFSH-25はスリーブ無しのみ

※上記以外にも、必要に応じて製作しております。

※メカニカルシール式の場合、形式TFS・TFSHの後にMが付いて
TFSM・TFSHMになります。

選定図

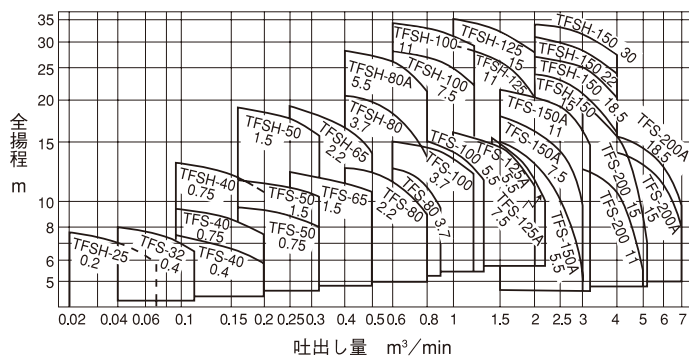
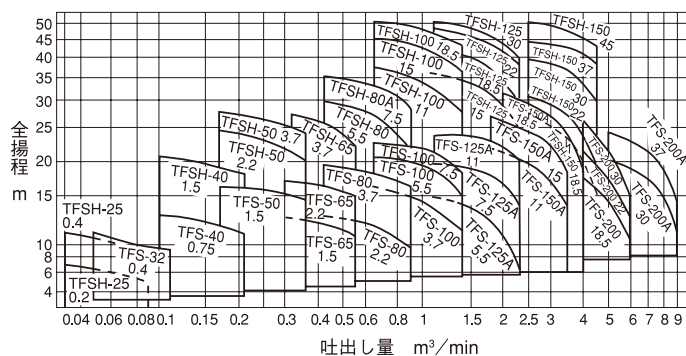
50Hz 同期速度 1500min⁻¹60Hz 同期速度 1800min⁻¹

TFS形・TFSSH形

仕様表

TFS形

50Hz同期速度1500min⁻¹

口径 mm	形 式	電動機 出力kW	吐出量 m ³ /min	全揚程 m	吐出量 m ³ /min	全揚程 m	吐出量 m ³ /min	全揚程 m
32	TFS-32	0.4	0.04	8	0.07	7.5	0.11	6.5
40	TFS-40	0.4	0.09	7.4	0.15	6.6	0.2	5.8
	TFS-40	0.75	0.09	9.3	0.15	8.5	0.2	7.5
50	TFS-50	0.75	0.16	9.4	0.25	8.8	0.32	8
	TFS-50	1.5	0.16	11.5	0.25	11	0.32	10.2
65	TFS-65	1.5	0.25	12	0.4	11.2	0.5	10.6
80	TFS-80	2.2	0.4	12.5	0.6	11.4	0.8	9
	TFS-80	3.7	0.6	12.5	0.7	12	0.9	9.5
100	TFS-100	3.7	0.6	15	0.9	14	1.2	12
	TFS-100	5.5	0.8	15	1	14	1.3	11.5
125	TFS-125A	5.5	1	16	1.5	14.5	2	11
	TFS-125A	7.5	1.4	15.5	1.8	13	2.2	10
150	TFS-150A	5.5	1.5	15	2.5	10	3	5
	TFS-150A	7.5	1.5	17.8	2.5	14	3	9
	TFS-150A	11	1.5	21.4	2.5	19	3.2	14.5
200	TFS-200	11	3	12.5	4	10.5	5	5.5
	TFS-200	15	3	19.5	4	15.7	5.2	7
	TFS-200A	15	4	14	5.5	12	7	8
	TFS-200A	18.5	4	15.5	5.5	13.5	7	9.5

60Hz同期速度1800min⁻¹

口径 mm	形 式	電動機 出力kW	吐出量 m ³ /min	全揚程 m	吐出量 m ³ /min	全揚程 m	吐出量 m ³ /min	全揚程 m
32	TFS-32	0.4	0.05	11	0.08	10	0.11	9
40	TFS-40	0.75	0.1	12.7	0.15	12	0.21	10.8
50	TFS-50	1.5	0.17	16	0.26	15.5	0.36	14.5
65	TFS-65	1.5	0.3	12.2	0.45	11.5	0.55	10.5
	TFS-65	2.2	0.3	16.7	0.45	15.8	0.55	15
80	TFS-80	2.2	0.42	12.5	0.65	11.5	0.9	9
	TFS-80	3.7	0.42	19	0.65	18	0.9	16
100	TFS-100	3.7	0.65	16	1	14	1.4	11
	TFS-100	5.5	0.65	20.4	1	19	1.4	15
	TFS-100	7.5	0.65	22.5	1	21.5	1.4	18
125	TFS-125A	5.5	1.1	14.5	1.7	12.5	2.3	6
	TFS-125A	7.5	1.1	19.2	1.7	18	2.3	13.5
	TFS-125A	11	1.1	23.5	1.7	23	2.3	20
150	TFS-150A	11	1.8	21.5	2.7	18.5	3.5	13.5
	TFS-150A	15	1.8	26.5	2.7	23.5	3.5	18
	TFS-150A	18.5	2	31	3	27	4	18
200	TFS-200	18.5	4	17	5	14	6	10
	TFS-200	22	4	21	5	17	6	12
	TFS-200	30	4	26	5	21	6	15
	TFS-200A	30	5	20	7	17	9	11
	TFS-200A	37	5	24	7	21	9	14

TFSSH形

50Hz同期速度1500min⁻¹

口径 mm	形 式	電動機 出力kW	吐出量 m ³ /min	全揚程 m	吐出量 m ³ /min	全揚程 m	吐出量 m ³ /min	全揚程 m
25	TFSSH-25	0.2	0.02	7.6	0.04	7	0.06	6.2
40	TFSSH-40	0.75	0.09	13	0.15	12	0.2	10.5
50	TFSSH-50	1.5	0.16	19	0.25	17.5	0.32	15.5
65	TFSSH-65	2.2	0.25	19	0.4	16.5	0.5	14
80	TFSSH-80	3.7	0.4	20.5	0.6	18.2	0.8	13.5
	TFSSH-80A	5.5	0.4	28	0.6	26	0.8	21
100	TFSSH-100	7.5	0.6	28	0.9	26	1.2	22
	TFSSH-100	11	0.6	34	0.9	32	1.2	29
125	TFSSH-125	11	1	29	1.5	26	2	20
	TFSSH-125	15	1	35	1.5	32	2	27.5
150	TFSSH-150	15	2	24	3	21	4	16
	TFSSH-150	18.5	2	27	3	25	4	20.5
	TFSSH-150	22	2	31	3	28	4	24
	TFSSH-150	30	2	33.5	3	31.5	4	27.5

60Hz同期速度1800min⁻¹

口径 mm	形 式	電動機 出力kW	吐出量 m ³ /min	全揚程 m	吐出量 m ³ /min	全揚程 m	吐出量 m ³ /min	全揚程 m
25	TFSSH-25	0.2	0.03	7	0.05	6.5	0.08	5.3
	TFSSH-25	0.4	0.03	11.2	0.05	10.4	0.08	9
40	TFSSH-40	1.5	0.1	20.5	0.15	19.5	0.21	18
	TFSSH-50	2.2	0.17	24.5	0.26	22.5	0.36	20
50	TFSSH-50	3.7	0.17	27.5	0.26	26	0.36	24
	TFSSH-65	3.7	0.32	27	0.45	25	0.55	22
80	TFSSH-80	5.5	0.42	29.5	0.65	27	0.9	21.5
	TFSSH-80A	7.5	0.42	35	0.65	33	0.9	28
100	TFSSH-100	11	0.65	37.3	1	33.5	1.4	27.5
	TFSSH-100	15	0.65	45	1	42	1.4	36
	TFSSH-100	18.5	0.65	50	1	47.5	1.4	42.5
125	TFSSH-125	15	1.1	35.5	1.7	32	2.3	25
	TFSSH-125	18.5	1.1	42	1.7	37.5	2.3	30
	TFSSH-125	22	1.1	48	1.7	44	2.3	38
	TFSSH-125	30	1.1	50	1.7	46	2.3	40
150	TFSSH-150	18.5	2.5	27	3.5	23	4.5	15
	TFSSH-150	22	2.5	30.5	3.5	27	4.5	19.5
	TFSSH-150	30	2.5	39	3.5	36	4.5	30
	TFSSH-150	37	2.5	44	3.5	42	4.5	38
	TFSSH-150	45	2.5	49.5	3.5	47	4.5	42.5

TFS形・TFSSH形

■寸法図 (計画・実施の際は、ポンプ外形寸法図をご確認願います。)

TFS-32~65

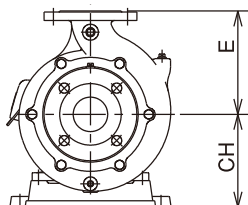

TFS-80~200A
TFSSH-25~150

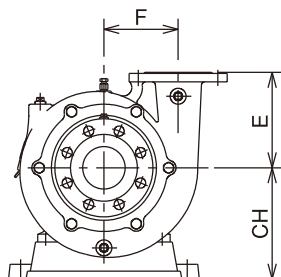

※()内…30kW以上

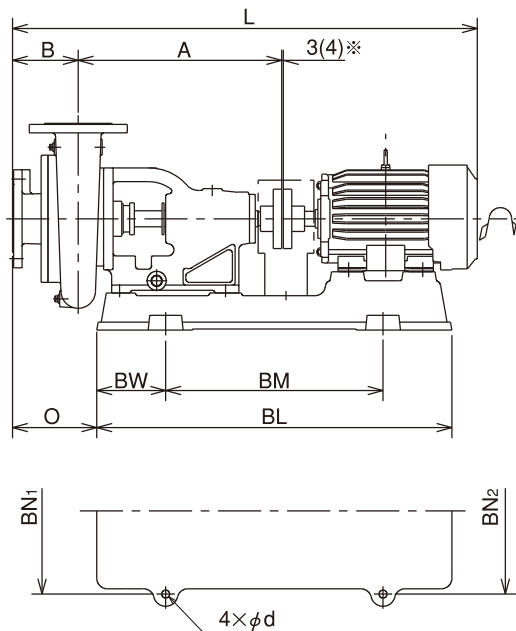

TFS

口径 mm	形式	電動機 出力 kW	外形寸法 mm											質量 kg			
			A	B	CH	E	F	L	O	BL	BM	BW	BN ₁		BN ₂	d	
32	TFS-32	0.4	277	74	160	139	—	601	98	476	296	90	212	212	12	38	
	40	TFS-40	0.4	280	99	160	170	—	629	126	476	296	90	212	212	12	40
		TFS-40	0.75	280	99	160	170	—	662	126	476	296	90	212	212	12	40
50	TFS-50	0.75	318	94	175	186	—	695	131	575	375	100	266	266	12	49	
	TFS-50	1.5	318	94	175	186	—	738	131	575	375	100	266	266	12	48	
65	TFS-65	1.5	318	112	175	195	—	756	149	575	375	100	266	266	12	51	
	TFS-65	2.2	318	112	175	195	—	804	154	575	375	100	266	266	12	56	
80	TFS-80	2.2	384	124	210	180	140	882	159	670	410	130	314	314	15	82	
	TFS-80	3.7	384	124	210	180	140	897	159	670	410	130	314	314	15	84	
100	TFS-100	3.7	416	136	225	192	153	941	173	700	440	130	344	344	15	103	
	TFS-100	5.5	416	136	240	192	153	1005	168	780	460	160	352	352	15	109	
		TFS-100	7.5	416	136	240	192	153	1043	168	780	460	160	352	352	15	109
125	TFS-125A	5.5	520	152	280	201	170	1125	194	877	577	150	390	390	15	142	
	TFS-125A	7.5	520	152	280	201	170	1163	194	877	577	150	390	390	15	143	
150	TFS-150A	11	520	152	280	201	170	1288	193	1010	700	155	402	402	19	158	
	TFS-150A	5.5	522	152	280	217	189	1127	198	877	577	150	390	390	15	162	
	TFS-150A	7.5	522	152	280	217	189	1165	198	877	577	150	390	390	15	162	
	TFS-150A	11	522	152	280	217	189	1290	197	1010	700	155	402	402	19	167	
	TFS-150A	15	522	152	280	217	189	1290	197	1010	700	155	402	402	19	171	
200	TFS-150A	18.5	529	152	285	217	189	1323	193	1080	720	180	436	436	19	176	
	TFS-200	11	598	180	360	250	210	1394	70	1242	742	250	570	410	19	293	
	TFS-200	15	598	180	360	250	210	1394	70	1242	742	250	570	410	19	293	
	TFS-200	18.5	598	180	360	250	210	1420	70	1282	782	250	570	444	19	309	
	TFS-200	22	598	180	360	250	210	1420	70	1282	782	250	570	444	19	309	
200	TFS-200	30	615	180	360	250	210	1516	72	1339	835	252	570	444	19	317	
	TFS-200A	15	598	180	360	250	210	1394	70	1242	742	250	570	410	19	285	
	TFS-200A	18.5	598	180	360	250	210	1420	70	1282	782	250	570	444	19	301	
	TFS-200A	30	615	180	360	250	210	1516	72	1339	835	252	570	444	19	309	
	TFS-200A	37	615	180	380	250	210	1619	67	1384	784	300	576	494	19	311	

注1：質量は電動機を含みません。注2：L寸法は電動機により異なります。
注3：回転方向は電動機側より見て右。

TFSSH

口径 mm	形式	電動機 出力 kW	外形寸法 mm											質量 kg		
			A	B	CH	E	F	L	O	BL	BM	BW	BN ₁		BN ₂	d
25	TFSSH-25	0.2	296	73	150	135	100	597	113	448	288	80	208	208	12	36
	TFSSH-25	0.4	296	73	160	135	100	619	116	476	296	90	212	212	12	37
40	TFSSH-40	0.75	320	84	175	150	122	730	123	575	375	100	266	266	12	54
	TFSSH-40	1.5	320	84	175	150	122	730	123	575	375	100	266	266	12	53
50	TFSSH-50	1.5	382	90	210	165	140	798	123	670	410	130	314	314	15	75
	TFSSH-50	2.2	382	90	210	165	140	846	123	670	410	130	314	314	15	74
50	TFSSH-50	3.7	382	90	210	165	140	861	123	670	410	130	314	314	15	75
	TFSSH-65	2.2	411	92	225	180	146	877	125	700	440	130	344	344	15	91
65	TFSSH-65	3.7	411	92	225	180	146	892	125	700	440	130	344	344	15	91
	TFSSH-80	3.7	416	93	225	180	156	898	131	700	440	130	344	344	15	90
80	TFSSH-80	5.5	416	93	240	180	156	962	126	780	460	160	352	352	15	97
	TFSSH-80A	5.5	416	107	240	214	186	976	140	780	460	160	352	352	15	111
	TFSSH-80A	7.5	416	107	240	214	186	1014	140	780	460	160	352	352	15	111
100	TFSSH-100	7.5	510	100	280	220	198	1101	134	877	577	150	390	390	15	151
	TFSSH-100	11	510	100	280	220	198	1226	133	1010	700	155	402	402	19	157
	TFSSH-100	15	510	100	280	220	198	1226	133	1010	700	155	402	402	19	157
125	TFSSH-100	18.5	517	100	285	220	198	1259	129	1080	720	180	436	436	19	163
	TFSSH-125	11	587	110	360	230	205	1313	-11	1242	742	250	570	410	19	239
	TFSSH-125	15	587	110	360	230	205	1313	-11	1242	742	250	570	410	19	239
	TFSSH-125	18.5	587	110	360	230	205	1339	-11	1282	782	250	570	444	19	254
	TFSSH-125	22	587	110	360	230	205	1339	-11	1282	782	250	570	444	19	254
150	TFSSH-125	30	604	110	360	230	205	1435	-9	1339	835	252	570	444	19	262
	TFSSH-150	15	587	110	360	240	220	1313	-11	1242	742	250	570	410	19	241
	TFSSH-150	18.5	587	110	360	240	220	1339	-11	1282	782	250	570	444	19	259
	TFSSH-150	22	587	110	360	240	220	1339	-11	1282	782	250	570	444	19	259
	TFSSH-150	30	604	110	360	240	220	1435	-9	1339	835	252	570	444	19	267
150	TFSSH-150	37	604	110	380	240	220	1538	-14	1384	784	300	576	494	19	265
	TFSSH-150	45	604	110	380	240	220	1538	-14	1384	784	300	576	494	19	265

注1：質量は電動機を含みません。注2：L寸法は電動機により異なります。
注3：回転方向は電動機側より見て右。